

Principal Building Products Ltd

Barbot Industrial Estate
Mangham Road
Rotherham S61 4RJ

Tel: 01709 728150 Fax: 01709 724975
e-mail: sales@pbpltd.co.uk
website: www.pbpltd.co.uk



Agrément Certificate
07/4456
Product Sheet 2

RHINOVENT BREATHABLE ROOF TILE UNDERLAYS

FOR USE IN COLD NON-VENTILATED ROOFS

This Agrément Certificate Product Sheet⁽¹⁾ relates to Rhinovent Breathable Roof Tile Underlays, for use in cold non-ventilated pitched roof systems.

(1) Hereinafter referred to as 'Certificate'.

CERTIFICATION INCLUDES:

- factors relating to compliance with Building Regulations where applicable
- factors relating to additional non-regulatory information where applicable
- independently verified technical specification
- assessment criteria and technical investigations
- design considerations
- installation guidance
- regular surveillance of production
- formal three-yearly review.

KEY FACTORS ASSESSED

Weathertightness — as part of a complete roof, the products will resist the passage of water and wind-blown snow and dust into the interior of the building (see section 6).

Risk of condensation — the products are low water vapour resistance (Type LR) underlays and can be used as part of a cold non-ventilated pitched roof system without specific provisions for ventilation (see section 7).

Wind loading — when installed on appropriately spaced battens, the products' physical properties are deemed adequate to resist the wind loads imposed on the underlay. The products will reduce the wind uplift forces acting on the roof covering (see section 8).

Strength — the products have adequate strength to resist the loads associated with the installation of the roof (see section 9).

Durability — under the normal conditions found in a roof space, the products will have a service life comparable to traditional roof tile underlays (see section 12).

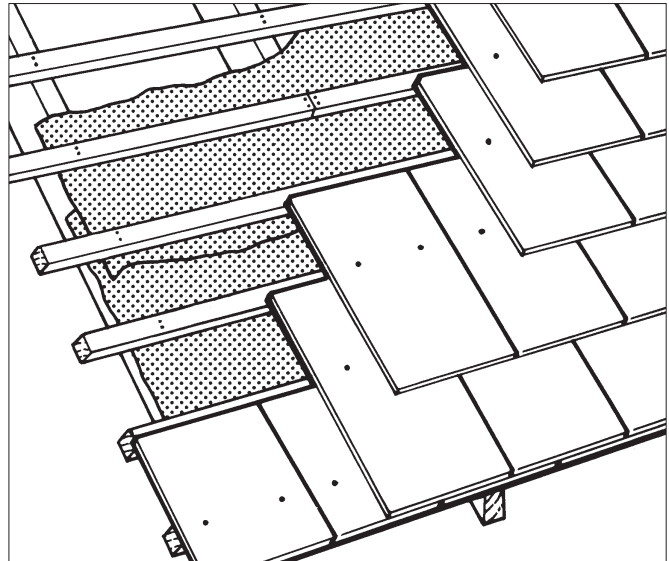

The BBA has awarded this Certificate to the company named above for the products described herein. These products have been assessed by the BBA as being fit for their intended use provided they are installed, used and maintained as set out in this Certificate.

On behalf of the British Board of Agrément

A handwritten signature in black ink, appearing to read 'Simon Wroe'.

A handwritten signature in black ink, appearing to read 'Claire Curtis-Thomas'.

Date of Third issue: 14 October 2013

Simon Wroe
Head of Approvals — Materials

Claire Curtis-Thomas
Chief Executive

Originally certificated on 27 July 2007

The BBA is a UKAS accredited certification body — Number 113. The schedule of the current scope of accreditation for product certification is available in pdf format via the UKAS link on the BBA website at www.bbacerts.co.uk

Readers are advised to check the validity and latest issue number of this Agrément Certificate by either referring to the BBA website or contacting the BBA direct.

British Board of Agrément
Bucknalls Lane
Watford
Herts WD25 9BA

©2013

tel: 01923 665300
fax: 01923 665301
e-mail: mail@bba.star.co.uk
website: www.bbacerts.co.uk

Regulations

In the opinion of the BBA, Rhinovent Breathable Roof Tile Underlays, if installed, used and maintained in accordance with this Certificate, will meet or contribute to meeting the relevant requirements of the following Building Regulations (the presence of a UK map indicates that the subject is related to the Building Regulations in the region or regions of the UK depicted):



The Building Regulations 2010 (England and Wales) (as amended)

Requirement:	C2(b)	Resistance to moisture
Comment:		The products will contribute to a roof meeting this Requirement. See section 6.1 of this Certificate.
Requirement:	C2(c)	Resistance to moisture
Comment:		The products will contribute to a roof meeting this Requirement with respect to interstitial condensation. See section 7 of this Certificate.
Regulation:	7	Materials and workmanship
Comment:		The products are acceptable. See section 12 and the <i>Installation</i> part of this Certificate.



The Building (Scotland) Regulations 2004 (as amended)

Regulation:	8(1)	Fitness and durability of materials and workmanship
Comment:		The use of the products satisfies this Regulation. See section 12 and the <i>Installation</i> part of this Certificate.
Regulation:	9	Building standards applicable to construction
Standard:	3.10	Precipitation
Comment:		The products will contribute to a roof satisfying clauses 3.10.1 ⁽¹⁾⁽²⁾ and 3.10.8 ⁽¹⁾⁽²⁾ of this Standard. See section 6.1 of this Certificate.
Standard:	3.15	Condensation
Comment:		The products can contribute to a roof satisfying this Standard with respect to interstitial condensation. See section 7 of this Certificate.
Standard:	7.1(a)	Statement of sustainability
Comment:		The products can contribute to meeting the relevant requirements of Regulation 9, Standards 1 to 6 and therefore will contribute to a construction meeting a bronze level of sustainability as defined in this Standard.
Regulation:	12	Building standards applicable to conversions
Comment:		All comments given for these products under Regulation 9, Standards 1 to 6 also apply to this Regulation, with reference to clause 0.12.1 ⁽¹⁾⁽²⁾ and Schedule 6 ⁽¹⁾⁽²⁾ . (1) Technical Handbook (Domestic). (2) Technical Handbook (Non-Domestic).



The Building Regulations (Northern Ireland) 2012

Regulation:	23(a)(i)(iii)(b)(i)	Fitness of materials and workmanship
Comment:		The products are acceptable. See section 12 and the <i>Installation</i> part of this Certificate.
Regulation:	28(b)	Resistance to moisture and weather
Comment:		The products will contribute to a roof satisfying this Regulation. See section 6.1 of this Certificate.
Regulation:	29	Condensation
Comment:		The products can contribute to a roof satisfying this Regulation. See section 7 of this Certificate.

Construction (Design and Management) Regulations 2007

Construction (Design and Management) Regulations (Northern Ireland) 2007

Information in this Certificate may assist the client, CDM co-ordinator, designer and contractors to address their obligations under these Regulations.

See sections: 1 *Description* and 14 *General* (14.2) of this Certificate.

Additional Information

CE marking

The Certificate holder has taken the responsibility of CE marking the products in accordance with harmonised European Standard BS EN 13859-1 : 2010. An asterisk(*) appearing in this Certificate indicates that data shown are given in the manufacturer's Declaration of Performance.

Technical Specification

1 Description

Rhinovent Breathable Roof Tile Underlays are composite structures, comprising water vapour permeable film and two layers of nonwoven polypropylene fabrics. The products have the nominal characteristics given in Table 1.

Characteristic (units)	Rhinovent Ultra	Rhinovent Pro
Thickness (mm)	0.40	0.50
Mass per unit area* ($\text{g}\cdot\text{m}^{-2}$)	112	125
Roll length* (m)	50, 100	50, 100
Roll width* (m)	up to 3	up to 3
Colour		
upper	Coloured	Grey
lower	White	White
Tensile strength* (N per 50 mm)		
longitudinal	270	290
transverse	155	170
Elongation* (%)		
longitudinal	60	50
transverse	70	60
Tear resistance* (N)		
longitudinal	105	125
transverse	100	120
Resistance to penetration of air ($\text{m}^3/\text{m}^2\cdot\text{h}\cdot 50\text{ Pa}$)	0.01	0.01
Watertightness*		
unaged	W1	W1
aged ⁽¹⁾	W1	W1
Water vapour transmission* (S_d) (m)	0.029	0.029
Vapour resistance ($\text{MN}\cdot\text{s}\cdot\text{g}^{-1}$)	0.145	0.145

(1) Aged in accordance with BS EN 13859-1 : 2010, Annex C.

2 Manufacture

2.1 The membrane is manufactured by lamination of a water vapour permeable film between two layers of non-woven polypropylene spunbond to form a flexible, vapour permeable roof tile underlay.

2.2 As part of the assessment and ongoing surveillance of product quality, the BBA has:

- agreed with the manufacturer the quality control procedures and product testing to be undertaken
- assessed and agreed the quality control operated over batches of incoming materials
- monitored the production process and verified that it is in accordance with the documented process
- evaluated the process for management of nonconformities
- checked that equipment has been properly tested and calibrated
- undertaken to carry out the above measures on a regular basis through a surveillance process, to verify that the specifications and quality control operated by the manufacturer are being maintained.

3 Delivery and site handling

3.1 Rolls are delivered to site individually wrapped in polythene. A technical leaflet bearing the product name is included with each roll and the BBA logo, including the number of this Certificate, is shown on the leaflet.

3.2 The rolls should be stored flat or on end, on a smooth, clean, dry surface, under cover and protected from sunlight.

Assessment and Technical Investigations

The following is a summary of the assessment and technical investigations carried out on Rhinovent Breathable Roof Tile Underlays.

4 Use

4.1 Rhinovent Breathable Roof Tile Underlays are satisfactory for use in dwellings with non-ventilated tiled or slated roofs of any conventional plan and of any size. Features⁽¹⁾ assessed include:

- duo pitched
- gable ends
- room-in-roof⁽²⁾
- mono-pitched
- verges
- dormers
- hipped
- abutments
- timber sarking⁽³⁾⁽⁴⁾
- mansard
- valleys.

- (1) For roofs incorporating other features, non-conventional roof geometries or construction materials, the advice of the Certificate holder should be sought.
- (2) Where a room-in-roof results in part of a roof pitch being insulated (ie a warm roof), design and detailing of that part of the roof should comply with relevant guidance given in Product Sheet 1.
- (3) As in Scottish practice, where slates are nailed through the breather membrane directly onto timber planks (nominally 150 mm wide with a 2 mm gap) without battens.
- (4) Timber sarking, tiled roofs: counter battens of 12 mm minimum thickness should be used to provide a drainage path beneath the tiling battens. The membrane may be laid directly over the timber planks or draped over the counter battens.

4.2 It is important that the designers, planners, contractors and/or installers ensure that the roof and ceiling are constructed in accordance with the Certificate holder's instructions and the information given in this Certificate.

4.3 The products can be installed by draping over rafters and securing with tiling battens, or installed taut over rafters and secured with counter battens and tiling battens, or supported over uninsulated timber plank sarking.

4.4 In conventionally-ventilated roof constructions, energy loss by ventilation can account for up to 25% of the total heat lost through the roof. The non-ventilated system will substantially reduce this mechanism of heat loss.

4.5 In non-ventilated roof systems, the risk of condensation is equivalent to, or less than, that for conventionally ventilated cold roof systems (see section 7).

5 Practicability of installation

The products are designed to be installed by competent roofers, experienced with this type of product.

6 Weathertightness



6.1 The products are classified as Class W1* in accordance with BS EN 13859-1 : 2010. The products will resist the passage of water, wind-blown snow and dust into the interior of a building, under all conditions to be found in a roof constructed in accordance with the relevant clauses of BS 5534 : 2003.

6.2 The products resist penetration of liquid water and consequently may be used as temporary waterproofing prior to the installation of slates or tiles. The period of such use should, however, be kept to a minimum. See BBA Information Bulletin No 2 *Permeable Roof Tile Underlay – Guide to Good Site Practice*.

7 Risk of condensation



7.1 For design purposes, the products' water vapour resistance may be taken as not more than $0.25 \text{ MN}\cdot\text{s}\cdot\text{g}^{-1}$, and for roofs designed in accordance with BS 5534 : 2003 or BS 5250 : 2011, Annex H, they may be regarded as a Type LR membranes.

7.2 The complete roof construction, ceiling boards to roof tiles, must be considered as a total system with regard to condensation risk. It is important that the products are laid in accordance with the Certificate holder's instructions and this Certificate to minimise the risk of condensation.

7.3 The risk of condensation is highest in new-build construction during the first heating period, where there is high moisture loading due to wet trades, such as in-situ cast concrete slabs or plaster. The risk of condensation diminishes as the building naturally dries out. See BBA Information Bulletin No 1 *Roof Tile Underlays in Cold Roofs during the Drying-out Period*.

7.4 All penetrations into and out of the roof space must be properly sealed in accordance with the Certificate holder's instructions which includes the use of the Certificate holder's recommended sealing tape. In addition, such features as vent stacks and boiler flues passing through the roof space must be sealed.

7.5 It is essential to minimise water vapour transfer into the loft space from the dwelling below. Appropriate measures include:

- ventilating the dwelling below in accordance with national Building Regulations and Standards for the dispersal and rapid dilution of water vapour, particularly from rooms that may experience high humidity (such as kitchens, utility rooms and bathrooms)
- covering all water tanks in the loft space and lagging pipework
- sealing penetrations in the ceiling and making loft hatches convection-tight by using a compressible draught seal
- ensuring that there is continuity of jointing with walls (and behind wall linings) at ceiling perimeters
- ensuring that masonry wall cavities do not interconnect with roof cavities.

7.6 For additional protection, the use of a vapour control layer/vapour check plasterboard can be considered.

8 Wind loading

8.1 Project design wind speeds should be determined and wind uplift forces calculated, in accordance with BS EN 1991-1-4 : 2005 and its UK National Annex.

8.2 The products, when fully supported by uninsulated timber plank sarking, have adequate resistance to wind uplift forces.

8.3 When the product is unsupported, wind loading should be calculated in accordance with BS 5534 : 2003 section 5.5.2.7. For acceptable wind loads with specific batten spacings for the draped product, using a 25 mm deep tiling batten, see Table 2.

Table 2 Resistance to wind loads

Batten spacing	Maximum pressure (kPa)	
	Rhinovent Ultra	Rhinovent Pro
350 mm	1.0	0.5
330 mm	1.0	–
300 mm	2.0	1.0
250 mm	2.5	2.5
200 mm	–	2.5

9 Strength

The products will resist the normal loads associated with installation of the roof.

10 Properties in relation to fire

10.1 The products achieve a Class D* classification in accordance with BS EN 13501-1 : 2002.

10.2 The products will have similar properties in relation to fire to those of traditional polyethylene roof tile underlays.

10.3 When the products are used unsupported, there is a risk that fire can spread if the materials are accidentally ignited during maintenance works, eg by a roofer's or plumber's torch. As with all types of underlay, care should be taken during building and maintenance to avoid the material being ignited.

10.4 When the products are used in a fully supported situation, the fire performance will be determined by the support.

11 Maintenance

As the products are confined within the roof space and have suitable durability (see section 12), maintenance is not required. However, any damage occurring before enclosure must be repaired (see section 16).

12 Durability



The products will be virtually unaffected by the normal conditions found in a roof space and will have a life comparable with that of traditional roof tile underlays, provided they are not exposed to sunlight for long periods (see section 14.5). Advice regarding exposure can be obtained from the Certificate holder.

13 Reuse and recyclability

The products comprise polyolefins, which can be recycled.

Installation

14 General

14.1 Rhinovent Breathable Roof Tile Underlays must be installed and fixed in accordance with the Certificate holder's instructions, provisions of this Certificate and the relevant recommendations of BS 5534 : 2003 and BS 8000-6 : 1990. Installation can be carried out under all conditions normal to roofing work.

14.2 The products have a high coefficient of friction, either wet or dry, giving a slip-resistant surface for increased safety during the installation of the tiles or slates.

14.3 The products are installed with the coloured or printed side uppermost and lapped to shed water out and down the slope.

14.4 Overlaps must be provided with the minimum dimensions given in Table 3.

Table 3 Minimum overlaps

Roof pitch (°)	Horizontal lap (mm)		Vertical laps (mm)
	Not fully supported	Fully supported	
12.5 to 14	225	150	100
15 to 34	150	100	100
35+	100	75	100

14.5 Where possible, eaves guards should be used to protect the product from sunlight and to direct water into the gutter.

15 Procedure

Draped and loose laps

15.1 The products should be installed as an unsupported system, and fixed in the traditional method for roof tile underlays, ie draped between rafters, with the coloured printed side uppermost.

Timber plank sarking

15.2 For fully supported roofs (traditional Scottish), the slates can be nailed through the product into the timber plank sarking, normally 150 mm wide with a 2 mm gap.

15.3 For fully supported roofs (where battens are used), counter battens of minimum thickness 12 mm should be installed either above or below the underlay, for drainage purposes.

16 Repair

Damage to the products can be repaired prior to the installation of slates or tiles by patching and sealing the damaged areas. Care must be taken to ensure that the watertightness of the roof is maintained.

17 Finishing

17.1 Detailing of abutments, verges and hips must be in accordance with the Certificate holder's instructions.

17.2 To achieve a convection-tight loft space, it is important that the following details are maintained (see also sections 7.4 and 7.5):

- all penetrations, eg pipework, electrical fittings to the loft space, must be sealed
- the loft hatch must be securely sealed to ensure a draught-free fit
- the insulation must be pushed into the eaves and against the underlay to avoid gaps.

17.3 The tiling and slating must be carried out in accordance with the relevant clauses of BS 5534 : 2003, BS 8000-6 : 1990 and the Certificate holder's instructions, especially when using tightly-jointed slates or tiles.

Technical Investigations

18 Tests

18.1 An assessment was made of data to BS EN 13859-1 : 2010 in relation to:

- dimensions*
- mass per unit area*
- tensile strength and elongation*
- resistance to tear*
- dimensional stability*
- resistance to water penetration*
- resistance to artificial ageing*
- resistance to penetration of air*
- water vapour transmission* .

18.2 Tests were carried out to determine:

- slip resistance
- resistance to streaming water
- Mullen burst strength
- resistance to wind loads

in order to assess:

- safety during installation
- performance under typical service conditions
- robustness during installation
- properties when installed.

19 Investigations

19.1 Using computer modelling, cold non-ventilated roofs were analysed for risk of condensation.

19.2 Test data on hydrostatic head were evaluated.

Bibliography

BS 5250 : 2011 *Code of practice for control of condensation in buildings*

BS 5534 : 2003 *Code of practice for slating and tiling (including shingles)*

BS 8000-6 : 1990 *Workmanship on building sites — Code of practice for slating and tiling of roofs and claddings*

BS EN 1991-1-4 : 2005 *Eurocode 1 : Actions on structures — General actions — Wind actions*

NA to BS EN 1991-1-4 : 2008 *UK National Annex to Eurocode 1 : Actions on structures — General actions — Wind actions*

BS EN 13501-1 : 2007 *Fire classification of construction products and building elements — Classification using test data from reaction to fire tests*

BS EN 13859-1 : 2010 *Flexible sheets for waterproofing — Definitions and characteristics of underlays — Underlays for discontinuous roofing*

BS EN ISO 9001 : 2008 *Quality management systems — Requirements*

Conditions of Certification

20 Conditions

20.1 This Certificate:

- relates only to the product/system that is named and described on the front page
- is issued only to the company, firm, organisation or person named on the front page — no other company, firm, organisation or person may hold or claim that this Certificate has been issued to them
- is valid only within the UK
- has to be read, considered and used as a whole document — it may be misleading and will be incomplete to be selective
- is copyright of the BBA
- is subject to English Law.

20.2 Publications, documents, specifications, legislation, regulations, standards and the like referenced in this Certificate are those that were current and/or deemed relevant by the BBA at the date of issue or reissue of this Certificate.

20.3 This Certificate will remain valid for an unlimited period provided that the product/system and its manufacture and/or fabrication, including all related and relevant parts and processes thereof:

- are maintained at or above the levels which have been assessed and found to be satisfactory by the BBA
- continue to be checked as and when deemed appropriate by the BBA under arrangements that it will determine
- are reviewed by the BBA as and when it considers appropriate.

20.4 The BBA has used due skill, care and diligence in preparing this Certificate, but no warranty is provided.

20.5 In issuing this Certificate, the BBA is not responsible and is excluded from any liability to any company, firm, organisation or person, for any matters arising directly or indirectly from:

- the presence or absence of any patent, intellectual property or similar rights subsisting in the product/system or any other product/system
- the right of the Certificate holder to manufacture, supply, install, maintain or market the product/system
- actual installations of the product/system, including their nature, design, methods, performance, workmanship and maintenance
- any works and constructions in which the product/system is installed, including their nature, design, methods, performance, workmanship and maintenance
- any loss or damage, including personal injury, howsoever caused by the product/system, including its manufacture, supply, installation, use, maintenance and removal
- any claims by the manufacturer relating to CE marking.

20.6 Any information relating to the manufacture, supply, installation, use, maintenance and removal of this product/system which is contained or referred to in this Certificate is the minimum required to be met when the product/system is manufactured, supplied, installed, used, maintained and removed. It does not purport in any way to restate the requirements of the Health and Safety at Work etc. Act 1974, or of any other statutory, common law or other duty which may exist at the date of issue or reissue of this Certificate; nor is conformity with such information to be taken as satisfying the requirements of the 1974 Act or of any statutory, common law or other duty of care.