

## Rhinoplast Ultra Radon Barrier

### Data Sheet

#### Product Description

A monolithic LDPE barrier designed primarily for use with Radon gas. Fully Radon Gas tested and approved by NSAI (IAB) Meets the requirements of BRE211. Standard roll size 4 x 20 metres. Available in red or grey. Thickness: 300mu (1200 gge)



#### Introduction

Radon (incl. Rn-222, Rn-220, RnD) is a naturally occurring radioactive gas which enters buildings from the underlying soil. The gas can accumulate within a building to such a concentration as to constitute a health hazard.

Radon is excluded from buildings using passive and active systems. The provision of a suitable protection system, designed and installed by competent personnel will substantially reduce the risk of a building having radon activity above a recommended target health level of 10-40 Bq/m<sup>3</sup> (USA).

Passive control systems consist of a radon resisting membrane extending across the whole of the building, including the floor and walls. These systems should also incorporate an underfloor ventilated sump or sumps which can be subsequently converted into an active control system by the use of suitable ventilation fans. A radon resisting membrane will also act as a damp proof membrane to protect the building against ingress of moisture from the ground.

#### Colour:

Grey

#### Technical Data:

Property	Test Method	Data
Weight		276g/m <sup>2</sup>
Thickness		300µm
Tensile Strength	MD	17.7MPa
	CD	17.3MPa
Elongation	MD	>860%
	CD	>910%
Dart Impact Strength		0.710kg
Tear Resistance	MD	100N/mm
	CD	94.5N/mm
Low Temperature Flexibility		-40°C
Radon Permeability		4.7x10 <sup>-12</sup> m <sup>2</sup> /s
MVTR		0.12g/m <sup>2</sup> /day
Standard Roll Width		4m
Standard Roll Length		20m
Standard Roll Weight		22.08kg

## Ancillary Components

### Rhinoplast Joint Strip

A butyl modified reinforced double sided bitumen tape, 1.5mm thick, designed to form a gas tight gasket. Excellent adhesion and tolerance to damp conditions.

**Colour:** black.

Available in: 50mm x 15m rolls,  
100mm x 15m rolls



### Girth Tape

A single sided girth tape used to secure and protect linear joints. Excellent adhesion, dimensionally stable and water resistant.

**Colour:** black.

Available in: 72mm x 50m rolls.



### Top Hats

A pre-formed pipe seal complete with stainless steel jubilee clip. Easily fixed and sealed on site.

Size range from 50mm to 200mm.

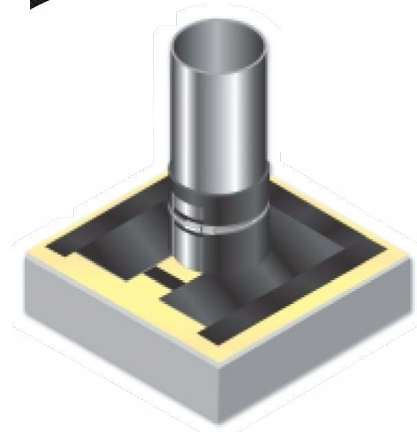

### Radon Sump Units

The Radoncare Sump and Cavity Gas Vent System is manufactured by a rotational moulding process from heavy duty polyethylene. The sump is constructed with a solid roof and base and is provided with 40mm diameter holes in the walls. Spigots for 100mm pipe connections are provided at each end of the sump, but are blanked off with knock outs to allow choice of direction for extract pipe. The cavity gas vent comes with a detachable polyethylene cap, which can be easily removed if an extraction system has to be attached.



### Useful References

The Building Regulations Approved Document Part C 2004, CP 102: 1973 code of practice for the protection of buildings against water from the ground.

**BR211** "Radon - Guidance on protective measures for new buildings"

**BRE414** "Protective measures for housing on gas-contaminated land"

**CIRA 665** Ground gas handbook 2009

**BS8485:2015** Code of Practice for the Characterization and Remediation from Ground Gas in Affected

Developments **NHBC** "Guidance on methane and carbon dioxide" and technical extra April 2016, issue 20.

Principal Building Products Ltd, Barbot Hall Industrial Estate,  
Mangham Road, Rotherham S61 4RJ | Telephone: 01709 728150  
Email: sales@pbpltd.co.uk

